

# **SL-T4234PTB120-L340**

## **PHOTO TRANSISTOR**

### **DATA SHEET**

SPEC. NO. : SZ19081206  
DATE : 2019/08/12  
REV. : A/0

Approved By:

Checked By:

Prepared By:

## Features

- ◆ Pb free product—RoHS compliant
- ◆ High Photo Sensitivity
- ◆ Reliable and rugged
- ◆ Long life – solid state reliability
- ◆ Sensitivity angle: 35°

## Package Dimension

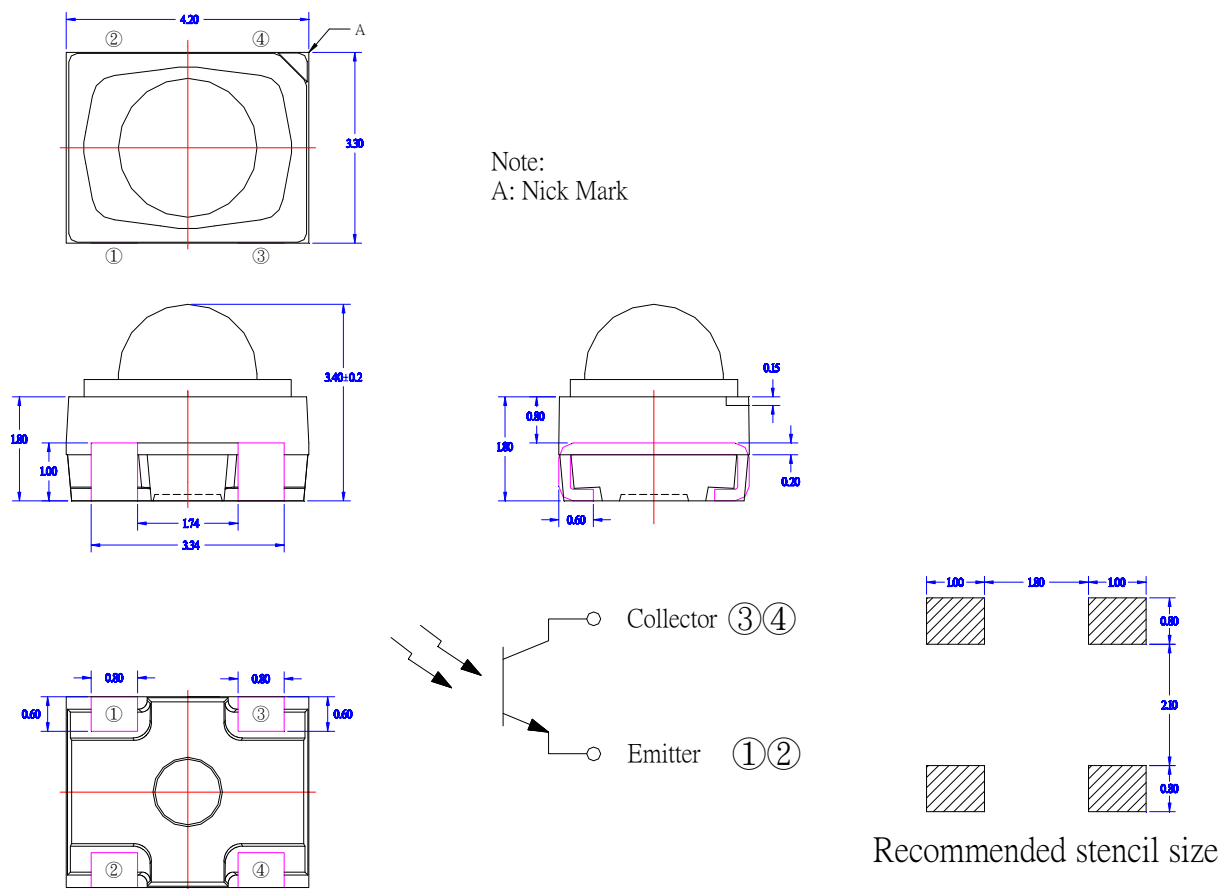

Part NO.	Chip Material	Lens Color
SL-T4234PTB120-L340	Silicon	Black

### Notes:

1. All dimensions are in millimeters.
2. Tolerance is  $\pm 0.10$ mm unless otherwise noted.
3. Specifications are subject to change without notice.

## Absolute Maximum Ratings at Ta=25°C

Parameter	MAX.	Unit
Power Dissipation	100	mW
Collector-Emitter Voltage	30	V
Emitter-Collector Voltage	5	V
Electrostatic Discharge (HBM) *2	8000	V
Moisture Sensitivity Level*1	5a	
Operating Temperature	-40°C to + 85°C	
Storage Temperature	-40°C to + 100°C	
Reflow Soldering Condition	260°C MAX. for 10 Seconds	

### 1. Storage:

- (1). Storage requirements before vacuum bag opened: Temperature<30°C, Humidity<65%RH;
- (2). Check air leakage and vacuum bag damage before opened. If there is any issue found, check the humidity indicator card immediately after bag opened:
  - a. If color changes on “10% circle” of the humidity indicator card only and not the circles of 20% and above, components can be used without additional handling;
  - b. If color changes on both 10% and 20% circles but not the circles of 30% and above, components must be dehumidified according to the conditions of bullet (5);
  - c. If color changes on 10%, 20%, and 30% circle or above, the product should be returned to the supplier for high temperature dehumidification;
- (3). After bag opened, manual soldering or reflow process must follow the following requirements:
  - a. Complete soldering / reflow within 24 hours;
  - b. Requirements of working environment: Temperature<30°C, Humidity<60%RH;
- (4). If the working condition is outside (3)a requirement, the components must be dehumidified according to the conditions of bullet (5);
- (5). Low temperature dehumidification: temperature 60±5°C, 24 hours;
- (6). Shelf life: 30 days. If it's over 30 days from the production date on the package label, the components must be dehumidified according to the condition of bullet (5). If customer is unable to dehumidify, return components to LIGHT for dehumidification.

### 2. Caution in ESD:

Static Electricity and surge damages the LED. It is recommend to use a wrist band or anti-electrostatic glove when handling the LED. All devices, equipment and machinery must be properly grounded.

## Electrical Optical Characteristics at Ta=25°C

Parameter	Symbol	Min.	Typ.	Max.	Unit	Test Condition
Collector-Emitter Breakdown Voltage	$BV_{CEO}$	30	---	---	V	$I_C=0.1mA$ $E_e=0mW/cm^2$
Emitter-Collector Breakdown Voltage	$BV_{ECO}$	5	---	---	V	$I_E=0.1mA$ $E_e=0mW/cm^2$
Collector-Emitter Saturation Voltage	$V_{CE(SAT)}$	---	---	0.4	V	$I_C=0.1mA$ $E_e=1mW/cm^2$
Viewing Angle(X)/(Y)	$2\theta_{1/2}$	---	35	---	Deg.	(Note 1)
Rise Time	$T_r$	---	15	---	$\mu s$	$V_{CE}=5V$ $R_L=1K\Omega$ $I_C=1mA$
Fall Time	$T_f$	---	15	---	$\mu s$	
Collector Dark Current	$I_{CEO}$	---	---	100	nA	$V_{CE}=10V$ $E_e=0mW/cm^2$
On State Collector Current	$I_{C(ON)}$	9.0	13.0	---	mA	$V_{CE}=5V$ $E_e=1mW/cm^2$ $\lambda_p=940nm$

### Note:

- $\theta_{1/2}$  is the off-axis angle at which the  $I_{C(ON)}$  is half the axial  $I_{C(ON)}$ .
- The  $I_{C(ON)}$  guarantee should be added  $\pm 15\%$  tolerance.

## Typical Electrical / Optical Characteristics Curves (25°C Ambient Temperature Unless Otherwise Noted)

FIG.1 Relative Response vs. Wavelength

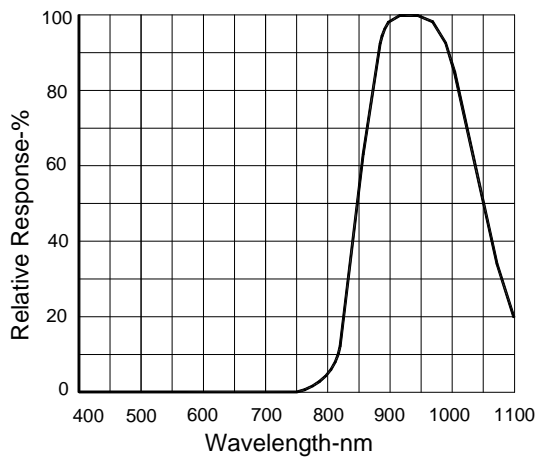

FIG.2 Power Dissipation Vs. Ambient Temperature

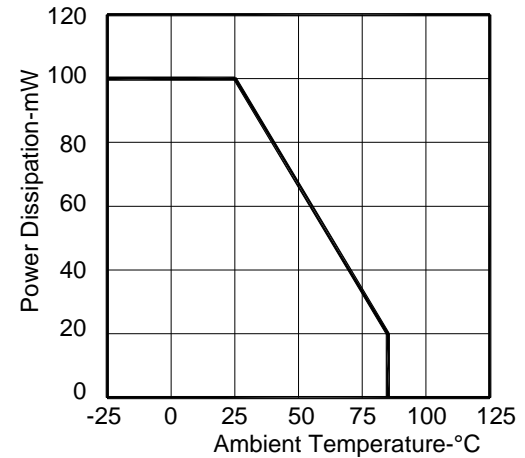

FIG.3 Rise And Fall Time Vs. Load Resistance

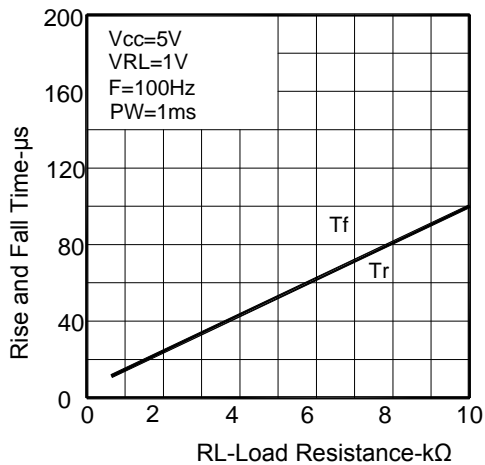

FIG.4 Relative Collector Current Vs. Irradiance

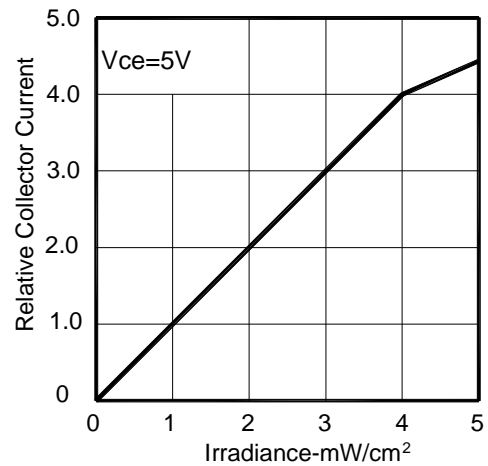

FIG.5 Collector Dark Current Vs. Ambient Temperature

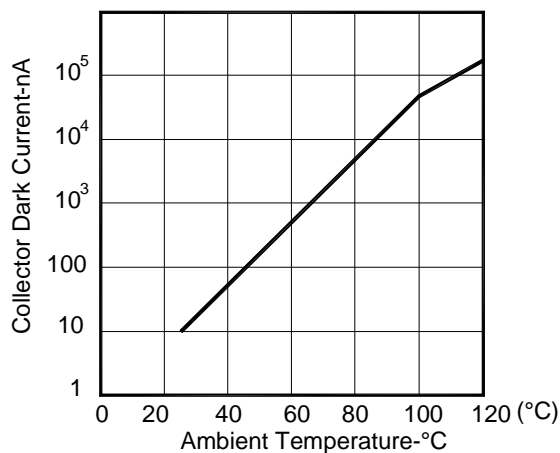
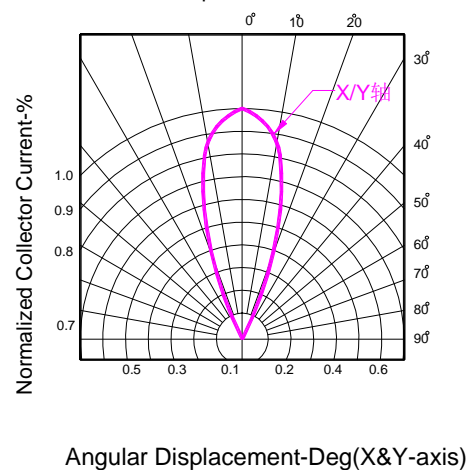

FIG.6 Light Current vs. Angular Displacement



### Photo Transistor Specification

●Commodity: Photo Transistor

●Ic(on) Bin Limits (VR=5V, Ee=1mW/cm<sup>2</sup>, λp=940nm)

BIN CODE	Min.(mA)	Max.(mA)
65	9.2	11.0
66	11.0	13.0
67	13.0	15.5
68	15.5	18.5

**NOTE:** The Ic(on) guarantee should be added ±15% tolerance.

## Label Explanation

### LIGHT Universal Label

<b>LIGHT</b> 深圳莱特光电股份有限公司  Light Electronics CO., LTD.	
产品型号 MODEL NAME:	 LOT NO.:
数量 QUANTITY:	
等级 BIN:	
包装日期 PACKING DATE:	
备注 REMARKS:	

### Customer Defined Label

<b>LIGHT</b> 深圳莱特光电股份有限公司  Light Electronics CO., LTD.	
产品型号 MODEL NAME:	 LOT NO.:
数量 QUANTITY:	
等级 BIN:	
包装日期 PACKING DATE:	
客户料号 CUSTOMER P/N:	

## Reel Dimensions

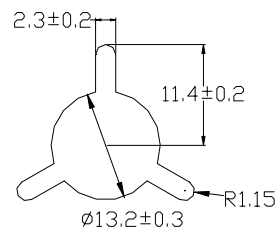
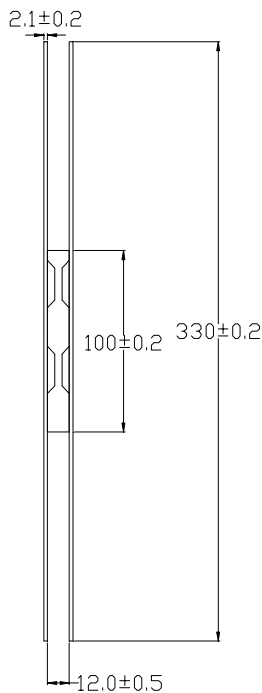
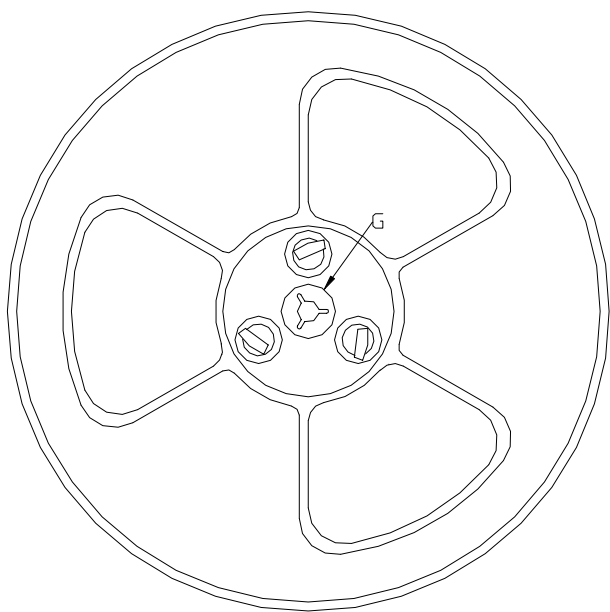

G区放大图

**Note:** Tolerance unless mentioned is  $\pm 0.2\text{mm}$ ; Unit = mm

### Carrier Tape Specifications (Loaded Quantity: 2200pcs/reel)

ITEM	W	A0	B0	K0	E	F	D0	P	P0	P2	T
DIM	12.00	3.50	4.40	3.90	1.75	5.50	1.50	8.00	4.00	2.00	0.35
TOLE	+0.30 -0.30	+0.10 -0.10	+0.10 -0.10	+0.10 -0.10	+0.10 -0.10	+0.10 -0.10	+0.15 -0.15	+0.10 -0.10	+0.10 -0.10	+0.10 -0.10	+0.05 -0.05

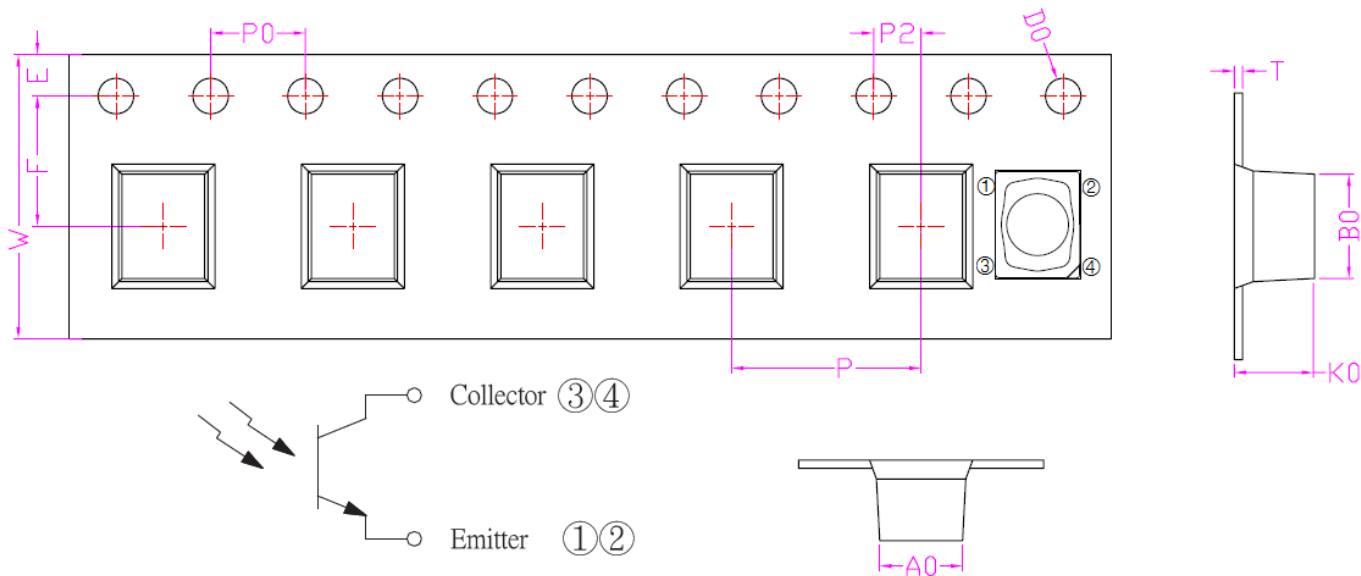

**Note:** Tolerance unless mentioned is  $\pm 0.1$ mm; Unit = mm

### Moisture Resistant Packaging

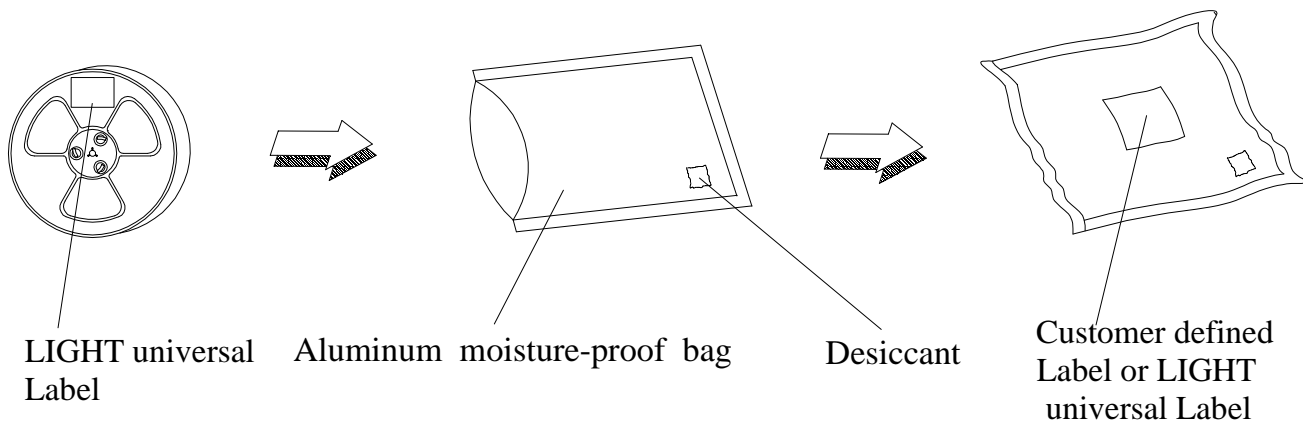



## Suggest IR Reflow Condition For Lead Free

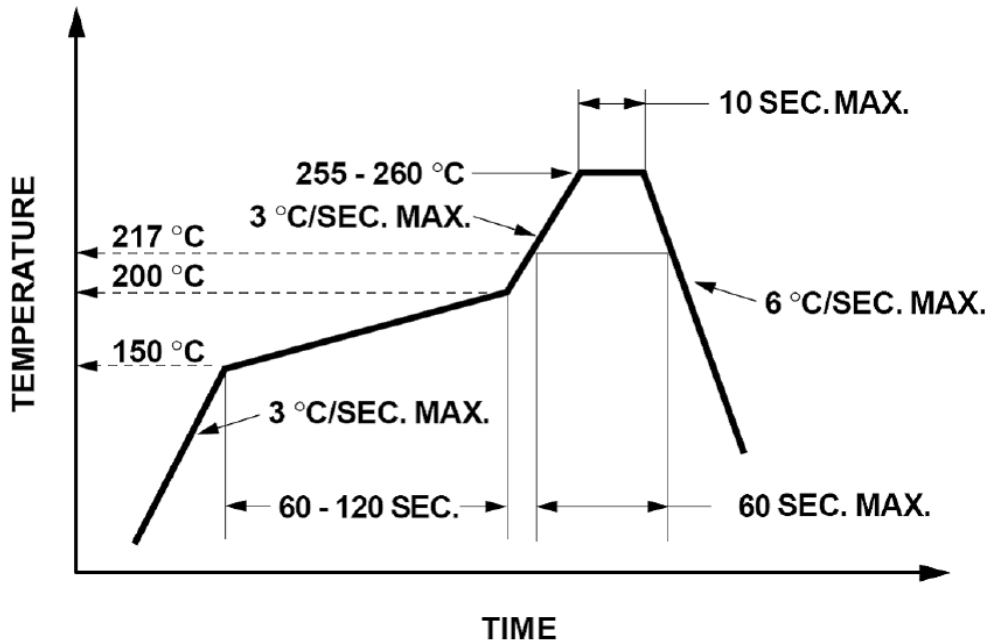

1. Reflow soldering should not be done more than two times.
2. When soldering, do not put stress on the LEDs during heating.

## Soldering iron

1. When hand soldering, the temperature of the iron must less than 300 °C for 3 seconds.
2. The hand solder should be done only once.

## Repairing

Repair should not be done after the LEDs have been soldered. When repairing is unavoidable, a double-head soldering iron should be used (as below figure). It should be confirmed beforehand whether the characteristics of LEDs will or will not be damaged by repairing.

